



WALKIE REACH TRUCK

ER15 SERIES



- Load Capacity 3300 lbs.
- Lift Height 138 -177 in.
- Side Shifting Forks
- Tilt
- EPS (Elec. Power Steer)
- Extended Reach 19.7 in.
- Free Lift 63" on ER15
- Extended Length 94 in.
- Curtis Instrument Controller
- Tilt 2/5 degree
- Mast Height 87.4-90.5 in.
- Batteries & Charger Included
- 3 Year Limited Warranty

ER15 SERIES

Superior quality, maneuverable, compact, and durable for all your material handling applications. Ideal for small aisles and areas.

WEIGHT CAPACITY: 3300 lbs. @ 24" load center

LIFT HEIGHT: 138" or 177" (11.5 ft. or 14.75 ft)

FORK LENGTH: 45.2"

MAST HEIGHT: 87-90.5"

TURNING RADIUS: 67"

TILT: 2/5 degree

EXTENDED REACH: 19.7"

FREE LIFTING HEIGHT: 63" (ER15)

BATTERY / CHARGER: 24V 350Ah,
24-volt Industrial batteries with external direct
connect 110A 110VAC plug-in automatic 24V/50A
charger (both Included)

BRAKING: Electromagnetic Brakes

SPEED TRAVEL: 3.7 mph empty; 3.5 mph loaded

LIFTING SPEED: 5.1 ips empty; 4 ips loaded

LOWERING SPEED: 4.7 ips empty; 5.3 ips loaded

DRIVE WHEELS: 8.25" x 2.5" Poly

LOAD WHEELS: (2) 8.25" x 2.5" Poly

HYDRAULICS LIFTING MOTOR: 24V 3000 Watt lifting motor with hardened chrome moly steel for durability.

DRIVE MOTOR: 24V 3000 Watt ACdrive motor for efficiency and high torque.

STEERING MOTOR: EPS (Electronic Power Steering) 24V 200 Watt

AC CONTROLLER: 24V CURTIS Instrument provides performance through entire range of speed; Constant travel speed regardless of load; Battery discharge indicator combination gauge.

BRAKES: Electro-magnetic braking for secure stopping power; Electronic neutral braking for accurate control.

OPERATOR CONTROLS: EPS (Electric Power Steering), tilt lifting, lowering, horn functions are located in the ergonomic handle; Belly button reverse safety feature allows the unit to stop and reverse to avoid collision or injury.

CHASSIS AND MAST: Robotic Welding; Heavy duty steel chassis with I-beam mast for durability; Telescoping mast.



Walkie Reach Truck

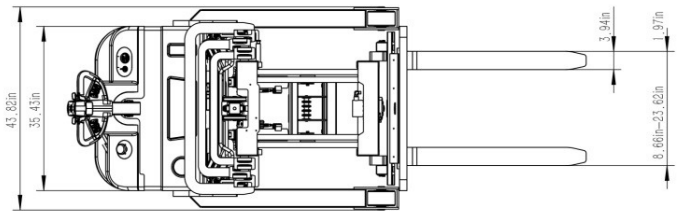
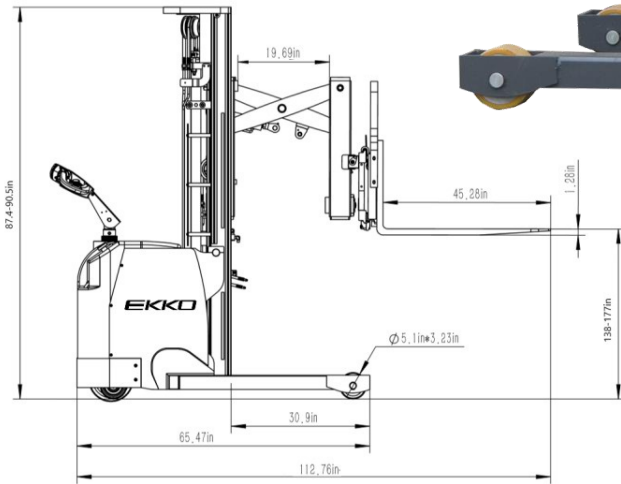

MODEL #	MAST	LIFT HEIGHT	MAX MAST HEIGHT	EXTENDED LENGTH	SERVICE WEIGHT
ER15	87.4"	177"	215"	112.76"	5500
ER15L	90.5"	138"	174"	112.76"	4800